

FULL HD-SDI 2.1MEGA PIXEL TRUE D&N BOX CAMERA

User's Manual

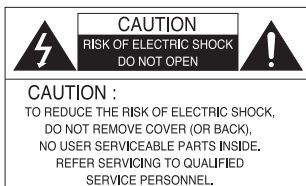



The lightning flash with an arrowhead symbol, within an equilateral triangle is intended to alert the user to the presence of uninsulated dangerous voltage within the product's enclosure that may be of sufficient magnitude to constitute a risk of electric shock to persons.



The exclamation point within an equilateral triangle is intended to alert the user to the presence of important operating and maintenance (servicing) instructions in the literature accompanying the appliance.

INFORMATION - This equipment has been tested and found to comply with limits for a Class A digital device, pursuant to part 15 of the FCC Rules & CE Rules. These limits are designed to provide reasonable protection against harmful interference when the equipment is operated in a commercial environment. This equipment generates, uses, and can radiate radio frequency energy and, if not installed and used in accordance with the instruction manual, may cause harmful interference to radio communications. Operation of this equipment in a residential area is likely to cause harmful interference in which case the user will be required to correct the interference at his own expense.

WARNING - Changes or modifications not expressly approved by the manufacturer could void the user's authority to operate the equipment.

CAUTION : To prevent electric shock and risk of fire hazards:

- ◆ Do NOT use power sources other than those specified.
- ◆ Do NOT expose this appliance to rain or moisture.

This installation should be made by a qualified service person and should conform to all local codes.

■ Contents

Features 6

Warning 7

Precautions 8

Components and Accessories 10

Names and functions of parts 11

Installation 14

How to Use the Camera ----- 18

- **Function Menu Structure** ----- 18

- **How to Set up the Functions** ----- 19

DISPLAY MODE 19

LENS 19

SHUTTER / AGC 20

AWB 20

PICT ADJUST 21

WDR/BLC/DNR 22

DAY/NIGHT 23

PRIVACY 24

MOTION DET 24

CAMERA ID 25

SYSTEM INFO 25

RESET ON 25

Troubleshooting ----- 26

Specification ----- 27

■ Features

Full HD-SDI Video

By adopting a 1/3" 2.1Mega Pixel Panasonic Progressive CMOS Sensor Produces high quality picture.

1920x1080p, 30fps / 1280x720p, 60fps

Excellent Low Illumination Sensitivity

By adopting highly sensitive color CMOS and digital signal processing technology, it can clearly distinguish the outline and color of a subject in an extremely low luminance environment even, for example, under starlight. Since surveillance is possible in places where the light is poor, the camera is appropriate for day and night surveillance outdoors or on the outside of buildings.

DNR(Digital Noise Reduction) Function

The high-performance DSP chip effectively removes low-light gain noise and ghosting to provide clear images even in dark environments.

Motion Detection

Since the camera detects motion and generates signals without any additional external sensor, you can monitor activity more efficiently by connecting the camera to an alarm device.

Alarm Out (option)

1/4" high density CCD allows the user to capture bright, high-quality images under ultra low lighting conditions.

Day & Night (ICR)

The camera identifies whether it is day or night and automatically switches to the appropriate mode, depending on its environment. By day, the camera switches to color mode in order to maintain optimal color. At night, it switches to B/W mode so as to obtain better picture definition.

Miscellaneous Functions

HLC(High Light Compensation), SENS-UP, FLIP(H/V-REV), D-ZOOM, SHARPNESS, MOTION DETECTION and PRIVACY functions are provided.

OSD

The camera' control is convenient using by 8 different foreign languages OSD.
- English, Italian, German

■ Warning

The camera requires periodic inspection.

Contact an authorised technician to carry out the inspection.

Stop using your camera when you find it malfunctioning.

If the camera emits smoke or is unusually hot for a long period, a fire may be caused.

Do not install the camera on a surface that can not support it.

If the camera is installed on an inappropriate surface, it may fall and cause injury.

Do not hold plug with wet hands.

It could cause an electric shock.

Do not dis-assemble the camera.

It may result in an electric shock or other hazards.

Do not use the camera close to a gas or oil leak.

It may result in a fire or other hazards.

■ Precautions

Do not install the camera in extreme temperature conditions.



Only use the camera under conditions where temperatures are between -10°C and $+50^{\circ}\text{C}$. Be especially careful to provide ventilation when operating under high temperatures.

Do not install or use the camera in an environment where the humidity is high.



It can cause the image quality to be poor.

Do not install the camera under unstable lighting conditions.

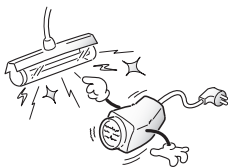

Severe lighting change or flicker can cause the camera to work improperly.

Do not touch the front lens of the camera.



This is one of the most important parts of the camera. Be careful not to leave fingerprints on the lens cover.

Do not drop the camera or subject it to physical shocks.



It can cause malfunctions to occur.

Never keep the camera pointed directly at strong light.

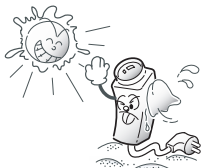

It can damage the Sensor.

Do not expose the camera to rain or spill beverage on it.



If it gets wet, wipe it dry immediately.
Liquids can contain minerals that corrode the electronic components.

Do not expose the camera to radioactivity.



If exposed to radioactivity the Sensor will fail.



Note

- If the camera is exposed to spotlight or object reflecting strong light, smear or blooming may occur.
- Please check that the power satisfies the normal specification before connecting the camera.

■ Components and Accessories

1. MEGA PIXEL BOX CAMERA

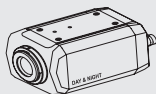

2. AUTO IRIS LENS CONNECTION PLUG

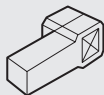

3. L-WRENCH

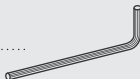

4. C-MOUNT ADAPTOR



5. CDS SENSOR



6. RCA FOR VBS - EXTRA



7. INSTRUCTION GUIDE



■ Names and Functions of Parts

Front

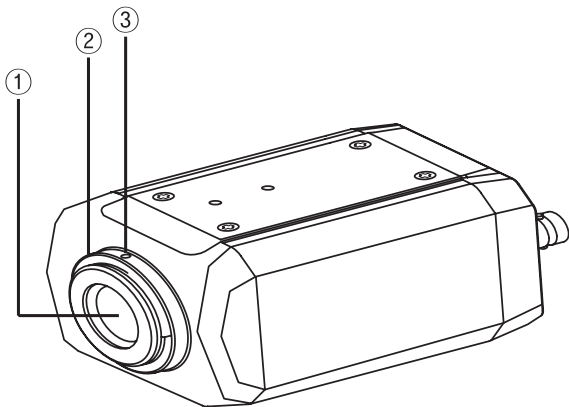

- ① **Lens Protection Cap**
Cover the lens when not using it.
- ② **CS-Mount Lens adaptor**
Attach the CS-Mount lens here.
- ③ **Back Focus Clamp Screws**
Loosen the clamp screw with a screwdriver before adjusting the Back Focal length.

Names and Functions of Parts

Bottom

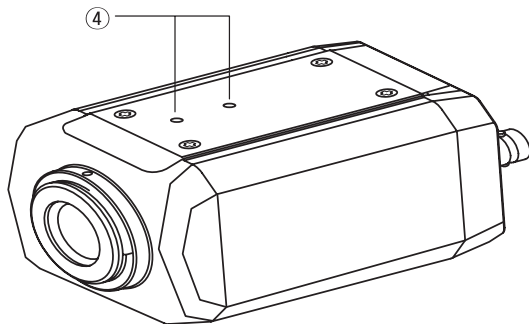

④ Mounting Bracket Screw Holes

Use the screw hole when fixing the camera onto the mounting bracket. Please use the clamp screw as specified in the picture.

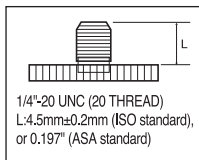

- ※ The mounting bracket can be separated and attached on the top of the camera.
please do not tighten the screw to a depth of more than 5mm, otherwise serious damage can occur to the inside of the camera.

■ Names and Functions of Parts

Side View



Rear View

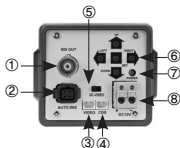

Set up and Function

- ① **SDI Output Port (BNC)**
 - SDI signals are output through this BNC type Port.
- ② **IRIS Connector**
 - Connect the IRIS plug of the Lens.
- ③ **Composit Video Out**
 - Video signals are output through this Port.
 - Connect to monitor through supplied cable.
- ④ **CDS Sensor Input**
 - Connect the supplied CDS sensor for proper ICR working if IR lamp used together. Set to "EXT" mode at "DAY/NIGHT" in "MENU" when use CDS sensor.
- ⑤ **Auto IRIS Selection Switch**
 - Change the mode to DC or VIDEO depending on the type of auto iris lens being used.
- ⑥ **Function Set Up Button**
 - SET Button : Displays the menu on the screen. Press the button to confirm status or after changing a selected item.
 - Up and Down Button : Used to move the cursor up or down in the menu screen to select a desired menu item.
 - Left and Right Button : Used to move the cursor left or right in the menu screen or to change the value of the selected item.
- ⑦ **Power Lamp**
 - Lights up when the correct power is supplied to the camera.
- ⑧ **Power Input Terminal**
 - Connect to the power appropriate to each power requirement.
 - DC12V Regulated only.

■ Installation

■ Lens

Lenses are sold separately. Lenses such as auto iris lens, CS-Mount lens and C-Mount lens can be used.



Note

- Use of the DC auto iris lens is recommended to achieve the best results for operating this product effectively.
- Keep the lens clean.
- Any foreign objects and fingermarks on the lens can cause inferior image quality in low light level conditions.

When using an auto iris lens

1. Peel off about 8mm of the outer skin of the auto iris lens cable.

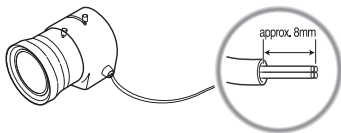

2. Peel off about 2mm of the outer skin of the insulated conductor inside the lens cable.

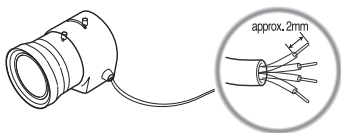

■ Installation

- Remove the cover of the auto iris lens connection plug and solder the lens cable to the connector pin in the plug.

Pin No.	LENS	
	DC	VIDEO
No.1 Pin	Damping-	Red(power)
No.2 Pin	Damping+	NC
No.3 Pin	Drive+	White(video signal)
No.4 Pin	Dreve-	Black(GND)

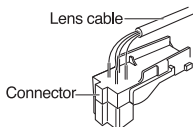
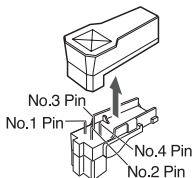

- Replace the auto iris lens connection plug cover and take off the lens protection cap, and then attach the auto iris lens to the camera by screwing it in clockwise.
- Insert the connection plug that is connected to the auto iris lens cable into the auto lens connector, which is located on the back of the camera.

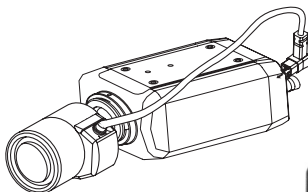

- Set the lens selection switch, located on the back of the camera, to DC or VIDEO depending on the type of auto iris lens which is being used.



■ Installation

When using a CS-Mount lens

Take off the lens protection cap and attach the CS-Mount lens to the camera by screwing it in clockwise.

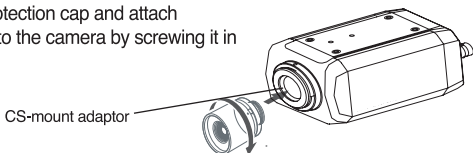

When using a C-Mount lens

1. Take off the lens protection cap and attach the C-mount adaptor.

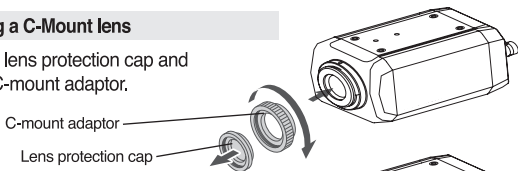

2. Attach the C-Mount lens to the camera by screwing it in clockwise.



Note

- Use the specified lens connection parts as shown in the picture below. The use of the wrong sized parts may cause damage to the inside of the camera or result in poor fitting.
- Use of a lens which is too heavy affects the balance of the camera and may cause a malfunction. Please use a lens that weighs less than 450g.
- Select Av mode if possible when adjusting the automatic light control (ALC) of an auto lens. Use of PK mode may cause hunting.

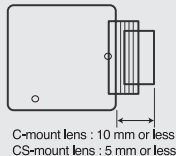

■ Connecting to a monitor

Connect the video output terminal located on the back of the camera to the monitor.

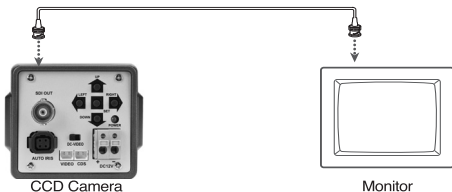

- The connection method varies depending on the type of monitor and accessories. Please refer to the user's manual for each instrument.
- Turn off the power when connecting.
- Please select Hi-Z on the 75 Ω /Hi-Z switch for the intermediate video TV set and select 75 Ω for the Intermediate device as shown in the picture below.

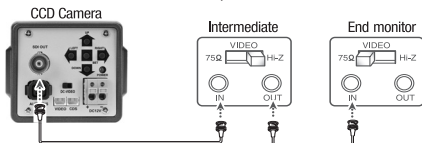

■ Connecting to power

Check the standard power requirement before connecting to power.

Dual Power Type
(AC 24V/DC 12V, AC 24V Class2)



■ How to Use the Camera

MAIN MENU			
■ DISPLAY MODE	▶ SDI SCALE	▶ SDI FORMAT	▶ SDI FPS
	▶ CVBS	▶ CVBS_RATIO	▶ FONT SIZE
	▶ COLOR BAR	▶ SHADINGT DET	▶ DEFECT DET
■ LENS	▶ MODE		
■ SHUTTER/AGC	▶ SHUTTER	▶ MODE	▶ AGC
	▶ DSS	▶ FREQ	
■ AWB	▶ MODE		
■ PICT ADJUST	▶ BRIGHTNESS	▶ GAMMA	▶ COLOR GAIN
	▶ ACE	▶ SHARPNESS	▶ MIRROR
	▶ FLIP	▶ STILL	▶ SHADING
	▶ DZOOM	▶ HLMASK	
■ WDR/BLC/DNR	▶ MODE	▶ WDR_WGT	▶ BLC OSD
	▶ BLC POS-X	▶ BLC POS-Y	▶ BLC SIZ-X
	▶ BLC SIZ-Y	▶ DNR	
■ DAY & NIGHT	▶ AUTO	▶ COLOR	▶ B&W
	▶ EXT		
■ PRIVACY	▶ MODE	▶ ZONE NO	▶ ZONE OP
	▶ X-POS	▶ Y-POS	▶ X-SIZ
	▶ Y-SIZ	▶ COLOR	▶ TRANS
■ MOTION	▶ OFF	▶ ON	
■ CAMERA ID	▶ MODE	▶ X-POS	▶ Y-POS
	▶ SETUP ID		
■ SYSTEM INFO	▶ VERSION	▶ DATE	▶ RESET DEFAULT ON(PUSHING)
■ RESET ON	▶ ON		
■ EXIT			

■ How to Use the Camera



Notes

- All item with the "┐", you can move to sub menu pressing SET button.
- An item with the "↓", push & hold menu button 3 second to settings.

■ DISPLAY MODE

- ▶ **SDI SCALE** : Compression SDI signal or not. FULL or COMP.
COMP shows bright image.
- ▶ **SDI FORMAT** : Select resolution. (1080P (1920X1080) or 720P(1280X720)).
- ▶ **SDI FPS** : Select frame per second. 30fps or 25fps.
- ▶ **CVBS** : Select format of composit video out. (NTSC or PAL).
(Composit video out deactivate at "WDR" mode under "WDR/BLC/DNR" in menu).
- ▶ **CVBS_RATIO** : Select CVBS ratio of composit video out. (16:9 or 4:3).
- ▶ **FONT SIZE** : Select font size of OSD. (x1 or x2).
- ▶ **COLOR BAR** : Color bar test. (ON or OFF).
- ▶ **SHADING DET** : Set to same brightness image of corner if image shaded by lens.
Shoot camera toward white paper in full screen and operate "ON" to write data in memory. To activate function, turn "ON" of "SHADING" under "PICT ADJUST" in menu.
- ▶ **DEFECT DET** : Remove white dead pixels in image. Close the lens and select to "ON". "THRS___00000006" will display. Set up to "00000030" by "RIGHT" button. Push the "MENU" key and hold it until disappear the menu.(Over 5 second).

■ LENS

- ▶ **MODE** : Select the lens type (DC/VIDEO/MANUAL).



Notes

- Please select correct lens mode by lens specifications.

■ How to Use the Camera

■ SHUTTER / AGC

- ▶ **SHUTTER** : Set shutter speed to AUTO or MANUAL (1/30 - 1/30,000).
DSS deactivate at "MANUAL".
- ▶ **MODE** : Select location of installed camera. "**INDOOR**" or "**OUTDOOR**".
Very important! If selection was not correctly, image able to show not clearly.
- ▶ **AGC** : Auto gain control. (0-20 Default : 13). **Day & Night & DNR deactivate if AGC "OFF"**.
- ▶ **DSS** : Digital slow shutter. (OFF/x2/x3/x4). **DSS deactivate at "MANUAL" mode of "SHUTTER"**. Camera detects the light level and maintains bright & clear image. (Sense-Up)
- ▶ **FREQ** : Select frequency. (50Hz or 60Hz).

■ AWB

- ▶ **MODE** : Set white balance.(AUTO,AUTO ext,PRESET(Push) or MANUAL (KELVIN/R-GAIN/B-GAIN)).
 - AUTO exe : Set color temperature for low temperature lamp at outdoor.
 - KELVIN : Set color temperature.(LOW/MIDDLE/HIGH).
 - R-GAIN : Set gain of RED color.(1-20).
 - B-GAIN : Set gain of BLUE color.(1-20).
- If white balance is not correct in "AUTO" mode at special area, use "PRESET" or "MANUAL" mode.



Notes

Mode : "Indoor or Outdoor"

- If selection is not made correctly, picture is showing unclear image.

■ How to Use the Camera

■ PICT ADJUST

- ▶ **BRIGHTNESS** : Control the brightness.(0-20).
- ▶ **GAMMA** : Gamma correction control.(0.5-0.75)
- ▶ **COLOR GAIN** : Color gain control.(0-20).
- ▶ **ACE** : Auto contrast enhancer.(ON or OFF).
- ▶ **SHARPNESS** : Control the sharpness.(0-15).
- ▶ **MIRROR** : Flip the image horizontally on the screen.(ON or OFF).
- ▶ **FLIP** : Flip the image vertically on the screen.(ON or OFF).
- ▶ **STILL** : Hold the captured image.(ON or OFF).
- ▶ **SHADING** : Activate of memorized shading data by "SHADING DET" under "DISPLAY MODE". (ON or OFF).
- ▶ **DZOOM** : Digital zoom.(0-4).
- ▶ **HL MASK** : Remove exceptionally bright light areas to allow detail image. (ON(Level 0-20) or OFF).
 - **COLOR** : Select color of masked area.(CYN/GRN/MAG/RED/BLU/BLK/WHT/YEL).

■ How to Use the Camera

■ WDR / BLC / DNR

- ▶ **MODE** : Set wide dynamic range & back light compensation & Digital noise reduction.(WDR or BLC)
 - WDR or BLC. (Composit video out deactivate at "WDR" mode).
The frame rate reduce from 30 to 15 at "WDR" mode.
- ▶ **WDR_WGT** : Control the weght range of WDR.(0-4).
- ▶ **BLC OSD** : Display the out line of BLC area.(ON/OFF).
- ▶ **BLCX-POS** : Select horizontal position of BLC zone.(0-20).
- ▶ **BLCY-POS** : Select vertical position of BLC zone.(0-20).
- ▶ **BLCX-SIZ** : Select horizontal size of BLC zone.(0-20).
- ▶ **BLCY-SIZ** : Select vertical size of BLC zone.(0-20).
- ▶ **DNR** : Digital noise reduction.(OFF/LOW/MIDDLE/HIGH).
DNR reduces the background noise in a low luminance environment.
DNR deactivate if AGC "OFF" of "SHUTTER/AGC" in menu.

■ How to Use the Camera

■ DAY & NIGHT

► **MODE** : Set display pictures in Color or Black and White.(AUTO/COLOR/B&W/EXT).
Day & Night deactivate if AGC "OFF" of "SHUTTER / AGC" in menu.

- **AUTO** : Color in a normal environment, switches to B/W mode at low ambient illumination.
 - **AGC THRS** : AGC Threshold level.(0-20).
 - **MARGIN** : AGC Margin level.(0-20).
 - **DELAY** : AGC delay.(0-10).
- **COLOR** : Always displayed in color.
- **B&W** : Always displayed in B&W.
- **EXT** : If supplied CDS sensor used for detect ambient visible illumination under 3-5lux, camera switches to B/W image.
 - **DELAY** : Delay to change B/W mode.(0-10).

■ How to Use the Camera

■ PRIVACY

Mask an 32 areas user want to hide on the screen.

- ▶ **MODE** : Activate privacy mode.ON/OFF.
- ▶ **ZONE NO** : Select zone number.(0-31 points).
- ▶ **ZONE OP** : Activate zone.ON/OFF.
- ▶ **X-POS** : Select horizontal position of zone.(0-60).
- ▶ **Y-POS** : Select vertical position of zone.(0-40).
- ▶ **X-SIZ** : Select horizontal size of zone.(0-40).
- ▶ **Y-SIZ** : Select vertical size of zone.(0-40).
- ▶ **COLOR** : Select color of masking area.(CYN/GRN/MAG/RED/BLU/BLK/WHT/YEL).
- ▶ **TRANS** : Select zone transparency.(0-4).

■ MOTION DET

This feature allows to observe movement of objects in 4 areas on the screen, and square lane appear on the screen when movement is detected.

- ▶ **OFF / ON** : Activate motion detection mode.(ON/OFF).
- ▶ **RESOLUTION** : Select motion resolution.(0-4).
- ▶ **SENSITIVITY** : Select motion sensitivity.(0-20).
- ▶ **WINDOW TONE** : Select window tone.(0-6).
- ▶ **WINDOW USE** : Select activate window.(ON/OFF).
- ▶ **X-POS** : Select horizontal position of window.(0-60).
- ▶ **Y-POS** : Select vertical position of window.(0-40).
- ▶ **X-SIZE** : Select horizontal size of window.(0-60).
- ▶ **Y-SIZE** : Select vertical size of window.(0-40).

■ How to Use the Camera

■ CAMERA ID

Display camera's ID

- ▶ **MODE** : Activate to display ID.(ON/OFF).
- ▶ **X-POS** : Select vertical position of ID.(0-119).
- ▶ **Y-POS** : Select vertical position of zone.(0-44).
- ▶ **SET UP ID** : Set up ID.

Push " ↵ " to display A to Z & numbers.

■ SYSTEM INFO

▶ **VERSION**

▶ **DATE**

▶ **RESET DEFAULT ON**

▶ **RETURN**

▶ **RESET DEFAULT**

▶ **VIDEO TYPE** ▶ NTSC / PAL

▶ **FONT SIZE** ▶ X1 / X2

▶ **LENS TYPE** ▶ Manual / DC / VIDEO

▶ **DAY&NIGHT** ▶ AUTO / B/W / COLOR / EXT

▶ **TDN SENSOR** ▶ LOW B/W / HIGH B/W

▶ **TDN DELAY** ▶ 0-10

▶ **DNR** ▶ OFF / LOW / MIDDLE / HIGH

▶ **LVDS DELAY** ▶ 0-10

■ RESET ON

- ▶ **ON** : Reset to factory default. Push 'MENU' button and hold until display 'PUSHING'.

When "RESET" carried out, "EXT" mode go to "AUTO" mode automatically, and composit video out go to "NTSC" mode automatically.

Please check all category of the "MENU" after "RESET".

■ Troubleshooting

PROBLEM	SOLUTION
Nothing appears on the screen.	<ul style="list-style-type: none"> ● Check that the power cord and line connection between the camera and monitor are fixed properly. ● When the camera's HD-SDI BNC output is directly connected to the monitor's BNC terminal. Make sure the monitor supports HD-SDI signal input. ● When the camera's HD-SDI BNC output is directly connected to the DVR. Make sure the DVR supports HD-SDI signal input. ● HD-SDI output is converted into format such as DVI and VGA by using video converter. connected to the DVR. Make sure the DVR supports HD-SDI signal input. Make sure the converter's HD-SDI input format supports the product's output video format.
The image on the screen is dim.	<ul style="list-style-type: none"> ● Is lens stained with dirt? Clean your lens with soft, clean cloth. ● Set the monitor to proper condition. ● If the camera is exposed to very strong light, change the camera position. ● Check the mode "Indoor or Outdoor"
The image on the screen is dark.	<ul style="list-style-type: none"> ● Adjust the contrast feature of the monitor.
The camera is not working properly, and the surface of the camera is hot.	<ul style="list-style-type: none"> ● Check that you have properly connected the camera to an appropriate power source.
The SENS-UP function does not work.	<ul style="list-style-type: none"> ● Check that AGC of EXPOSURE SETUP menu is 'OFF'.
The Motion Detection function does not work.	<ul style="list-style-type: none"> ● Check that MOTION DET of SPECIAL SETUP menu is 'OFF'.
Color is not correct.	<ul style="list-style-type: none"> ● Check the setting of WHITE BAL SETUP menu.
The screen flickers continually.	<ul style="list-style-type: none"> ● Ensure the camera is not pointing toward the sun. ● Is the camera traming the sun or other bright light source? ● HD-SDI video may not appear to be normal if distance exceeds the maximum transferrable distance. ● When a BNC cable adaptor is used to combine two or more BNC cables for distributed HD-SDI video transfer, make sure the impedance of the adaptor is 75Ω. Otherwise., it may cause shorter transfer distance or broken video transfer.

■ Specification

Item	
Imaging Sensor	1/3 Inch Panasonic CMOS, 2.1 Megapixel
Effective Pixels	(H)1944 x (V)1092
Signal System	HD-SDI
Scanning System	Progressive Scan
S/N Ratio	More than 50dB (AGC Off)
Display Pixels	1920x1080p(1080p/30fps), 1280x720p(720p/60fps)
Video Output Level	1.0Vp-p(75 ohms, Composite)/NTSC, PAL, 16:9, 4:3
IRIS Adjustment	Manual/DC/Video
Min. Illumination	0.1 Lux (50IRE, F1.2, AGC MAX/IR Off) / 0.01 Lux (Sense-Up x4)
Sync System	Internal
O.S.D	Built-in
Shutter Speed	1/60(50)~1/30,000
White Balance	AUTO / PUSHING / MANUAL(Kelvin, R-Gain, B-Gain)
WDR	OFF/ON (X1~X15)
Backlight Compensation	OFF/ON
Digital Slow Shutter	OFF/ON (X2~X4)
AGC	(0~20 Level Adjustable)
Motion Detection	OFF/ON
Privacy Masking	OFF/ON (32 Areas)
Camera Title	OFF/ON
Day & Night	AUTO/COLOR/BW/EXT
Digital Zoom	0 ~ 112 steps
Mirror	OFF/ON
Flip(H-REV)	OFF/ON
Brightness	0 ~ 20 steps
Color Gain	0 ~ 20 steps
Sharpness	0 ~ 15 steps
HLC	OFF/ON
Supplied Voltage	DC12 ±10% / Option : AC24V DC12V Dual
Power Consumption	Max. 5W

Distributed by

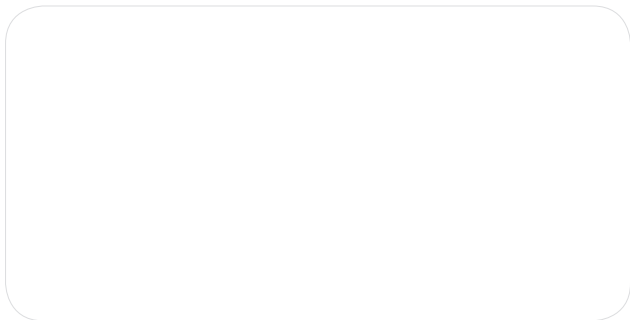
A large, empty rounded rectangular box with a thin grey border, intended for providing distribution information.