

WEATHERPROOF NETWORK SOUND PROJECTOR (POE)



▶ **CELL 10-IP** IP SOUND PROJECTOR

TECHNICAL SPECIFICATIONS

Rated power, Watts	10
Driver impedance, Ohms	8
Effective frequency range, Hz (BSEN60268-5)	120-18,000
S.P.L. @ 1m, 1 watt, dB, Test Signal Bandwidth 100Hz-10 kHz	91
S.P.L. @ Full power Octave Bandwidth, dB	101
Acoustic Power (dB-PWL@1 Watt) 1k/2k Hz, dB	87/90
Dispersion at 1k/2k Hz, Degrees	180/120
Directivity Axial Q factor, 1k/2kHz	2.8/5.9
IP Rating	55
Max/Min Ambient Temp	70°/-25°
Dimensions, front & depth, mm	Ø140 x 191
Net weight, Kgs	2.2
Colour/Finish White	RAL9016
Material	Aluminium with Stainless Steel hardware
Mounting	Aluminium U bracket

- ▶ Power supply PoE+ 24VDC power transformer (18 - 24VDC), minimum powers supply: 2A

WEATHERPROOF NETWORK SOUND PROJECTOR (POE)

> CELL10-IP IP SOUND PROJECTOR

FRONT VIEW

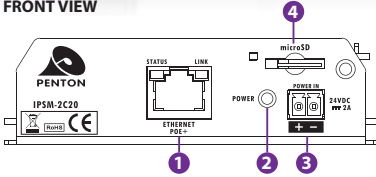

- 1 Ethernet port with PoE+ (25W) power
- 2 Power LED indicator
- 3 Optional external power input (24 ~ 27 VDC), PSU65-27 (65W) and PTR-2415 (36W) recommend
- 4 Micro SD Card interface

REAR VIEW

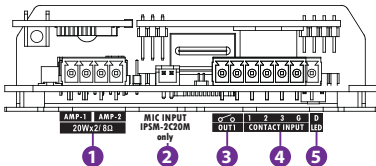

- 1 20W x 2 Channels amp output (8 ohm load speaker) or bridged 40W x 1 Channel amp output (4 ohm load speaker)
- 2 Optional mic input with model CELL10-IPM. Recommended optional microphone capsule model YMCO101-005
- 3 1 relay contact output can be programmed to control an external device
- 4 3 programmable contact inputs are controlled by external remotes such as source selector and volume control
- 5 LED interface (3.3V@10 mA): for safety and emergency alerting

front view unit: mm

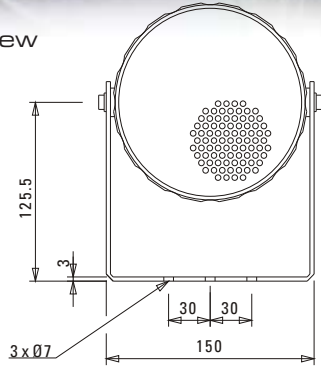

side view unit: mm

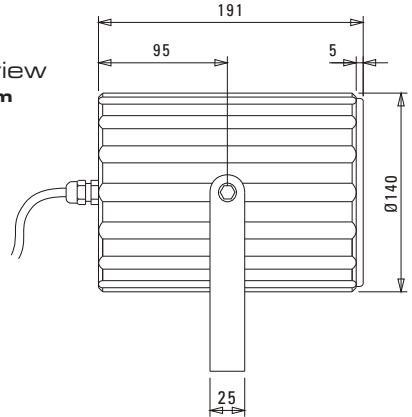

speech octave band sensitivity

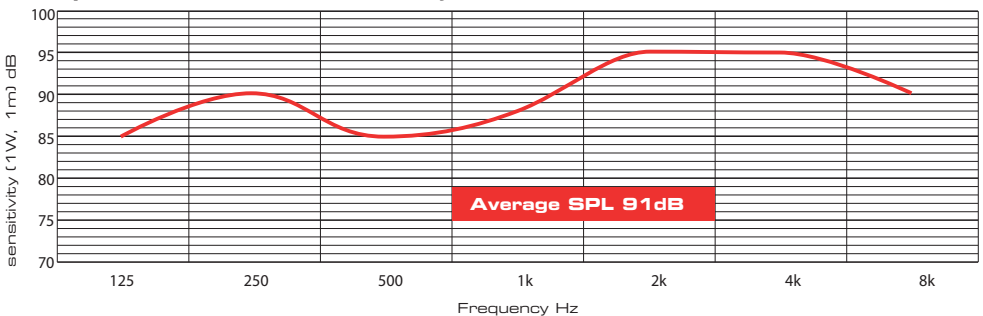

Effective Frequency Range **CELL10-IP** 120Hz - 18,000Hz



Penton UK Ltd

Unit 2 Teville Industrials | Dominion Way | Worthing | West Sussex | BN14 8NW
T: +44 (0)1903 215315 | F: +44(0)1903 215415 | E: SALES@PENTONUK.CO.UK

www.pentonuk.co.uk

