

## Anti climb guards

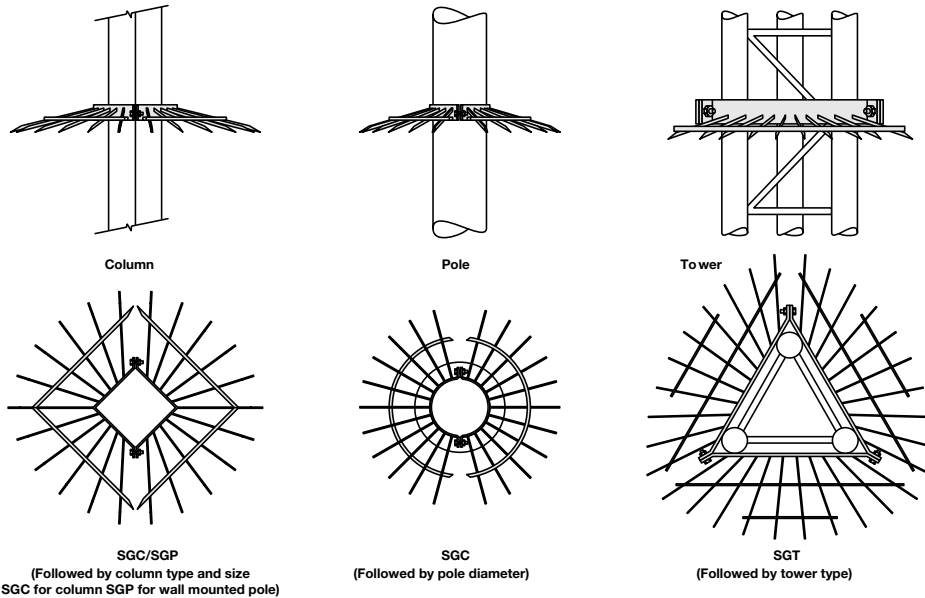

## Ladder stays

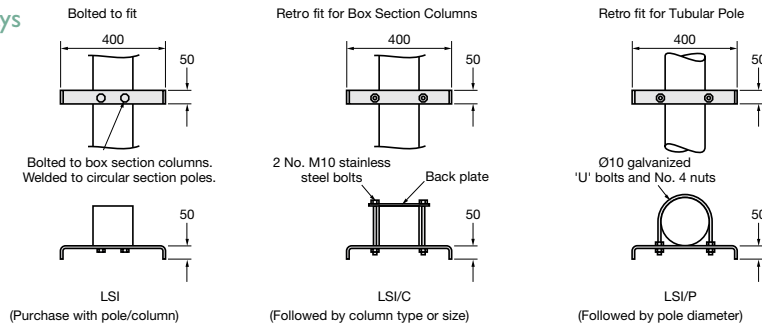

## Adjustable telemetry receiver brackets

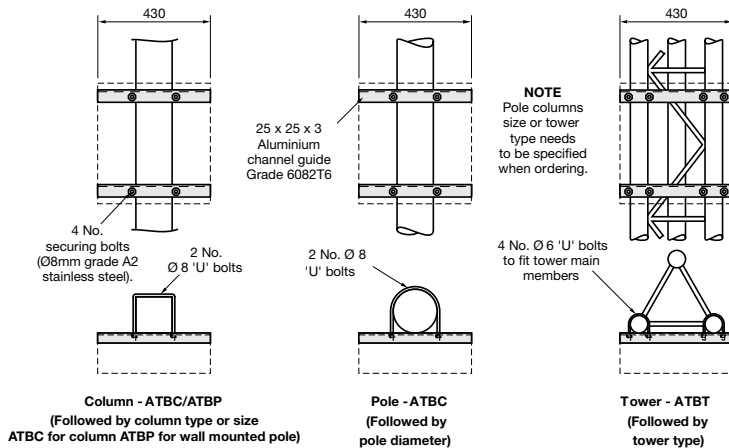

### Fitting adjustable telemetry receiver bracket

1. Drill aluminium channels to fit hole centre on receiver box (one channel across the bottom, one across the top)
2. Bolt channels to the box
3. Trim channels to the width of the box using hacksaw
4. Bolt the box to the column/pole/tower using the 'U' bolts supplied